

Proportional Control Unit (PCU - A)

[Installation & Maintenance Manual](#)

Version A4 2010.08

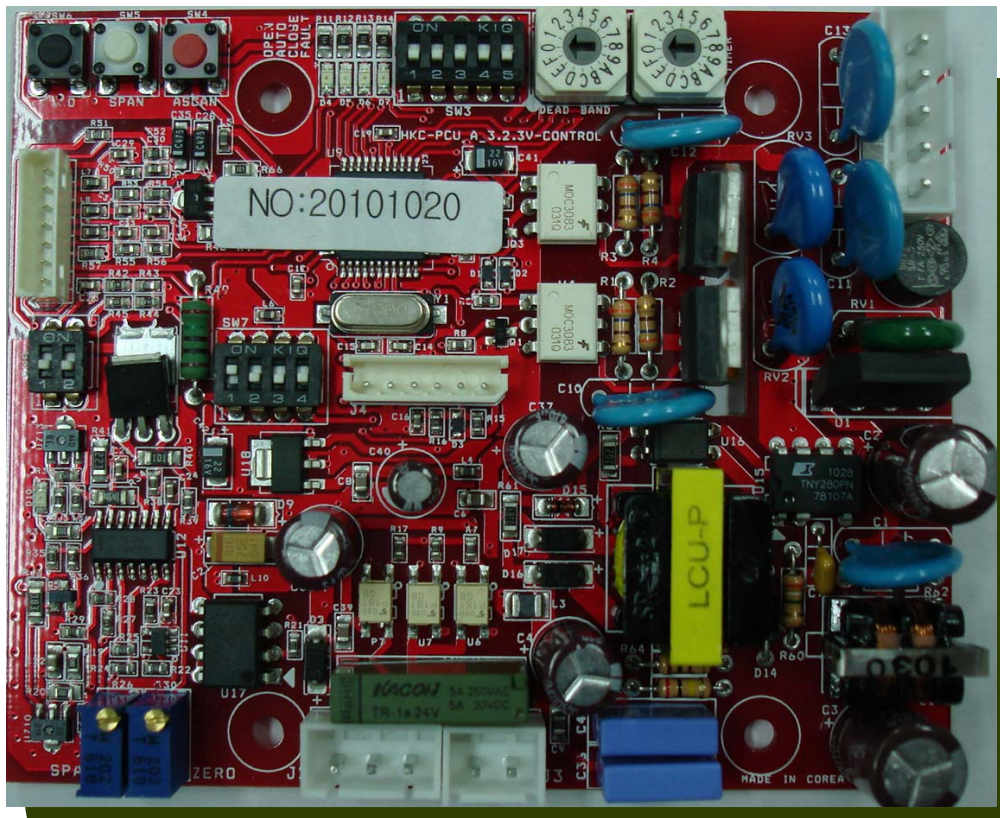

Table of contents

1. Check point before using actuator
2. General
3. Standard specification
4. Function of PCU and how to set and to use it
 - 1) Select Input signal
 - 2) Set DIP switch for fail position
 - 3) Delay time
 - 4) Resolution
 - 5) Manual operation
 - 6) Special setting for full open and close
 - 7) Auto-setting
 - 8) Split range (CH1)
 - 9) Reversal acting switch(CH2)
 - 10) Select output signal
5. Special tools
6. Setting potentiometer (Replacing and setting)
7. Limit switch setting
8. Check operation of PCU
9. Layout of PCU

*Thanks for purchasing our HQ series electric actuator.

Before installing or operating actuator, please read to this manual to know thoroughly how to install or operator.

The contents in this manual is subject to change due to the quality improvement without individual notice.

1. Check point before using actuator

- 1) Check if specification (Model No, Main Power, Control Power, Options) of delivered actuator meets your requirement or not.
- 2) Check the application such as valve, Damper & etc.
- 3) Check if mounting of actuator on application is correct and tight enough.
- 4) Check if settings of actuator such as limit switch, stopper bolts, indicator is correct or not.
- 5) Check if electric wiring is correct or not.
- 6) In case of 3 phase motor, check rotating direction.
 - ☞ Check rotating direction of actuator
 - Open actuator about 50% by manual, supply power to actuator for 2~3 second.
 - Push close button and check if actuator move close direction or not.
 - If yes, it is O.K, but reverse, stop to supply power to actuator and change the 2 power lines each other among 3 lines.
- 7) Generally all function of PCU is set by factory before delivery and no need to set the functions again.
 - Only in case that customer wants to adjust the limit switches, to set the function of PUC is required.
 - Setting is so simple and customer just pushes the AUTO SETTING button after putting actuator about 50% open (or close) position.
 - PCU automatically accomplishes to set all the functions by itself.
- 8) Disassembly, modification without factory's consent may affect the performance of the actuator.

2. General performance

PCU is the local actuator controller, using 12bit A/D converter and 8 bits Microprocessor, which operate actuator to open and close according to the input signal from main controller.

After operating actuator, detect the current position of actuator and transmit feedback output signal about current position to the main controller.

3. Standard specification

- 1) Model: PCU REV A4
- 2) Power : 85V~260VAC ±10% 50/60Hz 4VA Max (NEW Wide range of voltage)
- 3) Input signal: 4~20mA DC, 2~10VDC, 0~5VDC, 0~10VDC, 1~5VDC
Input resistance: 250 Ohm, Feedback signal: 100 ~ 10Kohm
- 4) Output signal: 4~20mA DC, 2~10VDC, 0~5VDC, 0~10VDC, 1~5VDC
- 5) Load resistance: 500Ohm Max.
- 6) Control output : TRIAC contact 250VAC 16A Max (Inductive load)
- 7) Number of output contact: 2 ea (Open and close contact)
- 8) Delay time adjustment: 0.05 ~ 7.5 sec (0Step 50msec 0~15Step)
1~4 Step (Step Number X 200msec) 5~15Step (Step Number X 500msec)
- 9) Dead Band adjustment: 0.12mA DC MAX
- 10) Resolution Adjustment: 0 Step: 0.068mA 0~15Step (Step Number+0.068mA)
- 11) Position conversation accuracy : ±0.5 ~ ±1.5%(Depends on installation)
- 12) Ambient temperature: -25°C ~ +80°C
- 13) Ambient humidity: 90% RH Max (Non-condensate)
- 14) Dielectric strength: 1500V AC 1Min (Input to output, Power to Ground)
- 15) Insulation resistance: Min. 500VDC 30Mohm
- 16) Vibration & Shock (X, Y, Z): 10g(6g based on RMF, Frequency: 0.2 ~ 34Hz,
30Min
- 17)LED signal

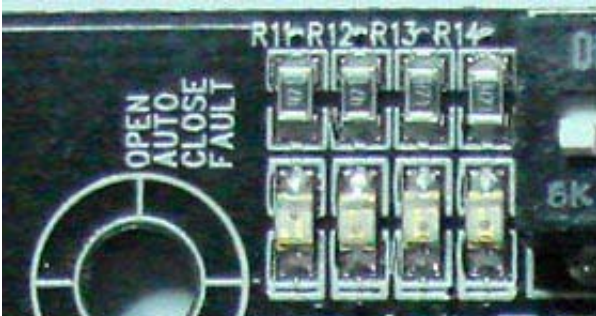
LED	SIGNAL	
Blue on	Power on(AUTO)	
Blue Flicker	AUTO SETTING	
Green Flicker	Closing	
Green on	Full Close	
Red Flicker	Opening	
Red on	Full Open	
Yellow on	Manual Mode	
Yellow Flicker	Fault in either No input signal, Wrong input wiring, Wrong PIU setting	

View A

4. Function of PCU and how to set and to use it

1) Selecting of input signal

User can select suitable input signal by adjusting DIP switches as follows.

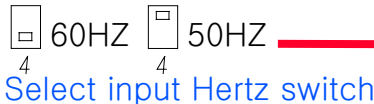
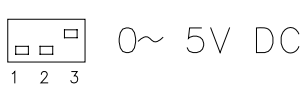
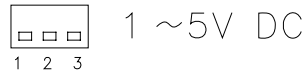
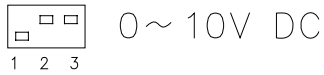
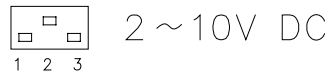
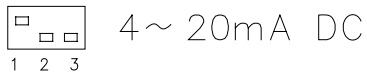

Select input signal switch

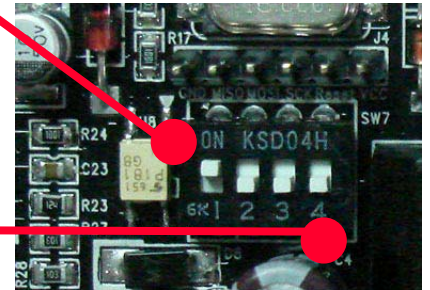

Select input Hertz switch

If there is no instruction for the input signal, factory set the signal as 4-20mA.

View B

2) Setting of fail position

In order to prevent big trouble when input signal is failed, user can set the fail position of actuator by setting of DIP switches as follows.

View C

Setting of fail position Switch(1,2)

Mode	Switch 1	Switch 2	Switch 3	Switch 4	Switch 5
FAIL CLOSE	Up	Down	Down	Down	Down
FAIL OPEN	Down	Down	Down	Down	Up
FAIL STOP	Down	Down	Down	Up	Down

3) Delay time

This prevents continuous operation of PCU card caused by abnormal signal input such as noise, microphone and other foreign frequency.

Once signal is detect, PCU follows that signal but if there is preset time, PCU doesn't move within the time.

PCU can move when input signal last a certain time which is preset.

Turning the switch to clockwise, delay time is getting longer.

(Range 0.05 ~ 7.5 sec (0Step 50msec 0~15Step))

1~4 Step (Step Number X 200msec)

5~15Step (Step Number X 500msec)

Delay time

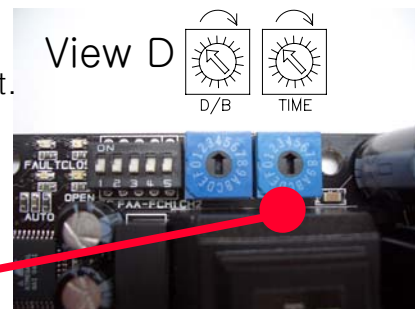

4) Resolution Adjustment

This is set allowance between input signal and position of actuator and if turn this to clockwise, it is getting wider. Vice versa.

Please be careful when turn this to counter-clockwise because if it is too narrow, it could be the reason of "HUNTING".

HUNTING is that actuator doesn't stop at a position and repeat to move to open and to close

Dead Band adjustment: 0.12mA DC MAX
Resolution Adjustment: 0 Step: 0.068mA
0~15Step (Step Number+0.068mA)

HUNTING could be the reason of motor burning, and damage of potentiometer and PCU card.

Resolution Adjustment

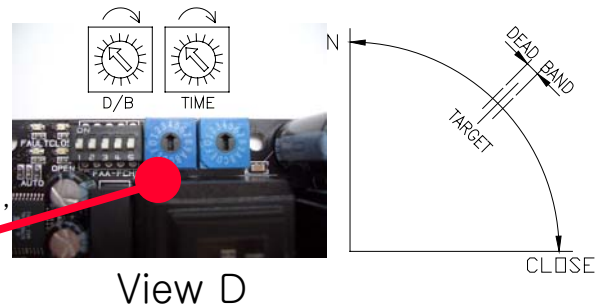

View D

5) Manual operation by PCU card.

In order to operate actuator by card, press ZERO and SPAN buttons together. for 2 second. Then yellow LED is on and this is manual operation mode.

If push zero button, actuator moves to close and if push span button, actuator moves to open.

Put as it is for 15 second without operation, PCU come out from manual operation mode.

(During manual operation mode, input signal is ignored)

Manual operation button

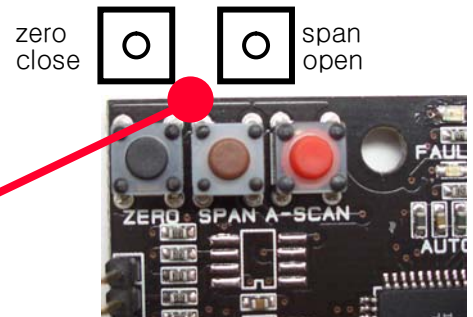

View E

6) Special signal setting for full open and full closed



View C

Special setting switch

"3" up	: Signal: 4.3mA	Full Closed
	Signal: 19.7mA	Full Open
"3" down	: Signal: 4 mA	Full Closed
	Signal: 20 mA	Full Open

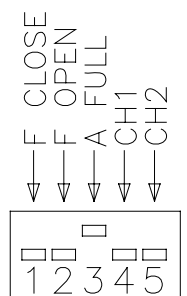

7) AUTO SETTING

If mounting between actuator and application is correct, and input signal, input power and wiring are correct, push AUTOSETTING button just 1 time regardless of the position of Actuator.

Then Blue LED flickers with indicating LED as following.

- 1) Opening with Red LED in 5 sec ->
- 2) Full Close with Green LED ->
- 3) Full Open with Red LED.

Notice : Please make sure that Limit Cam shall be touched (Open/Close) Limit Switch while Autosetting.

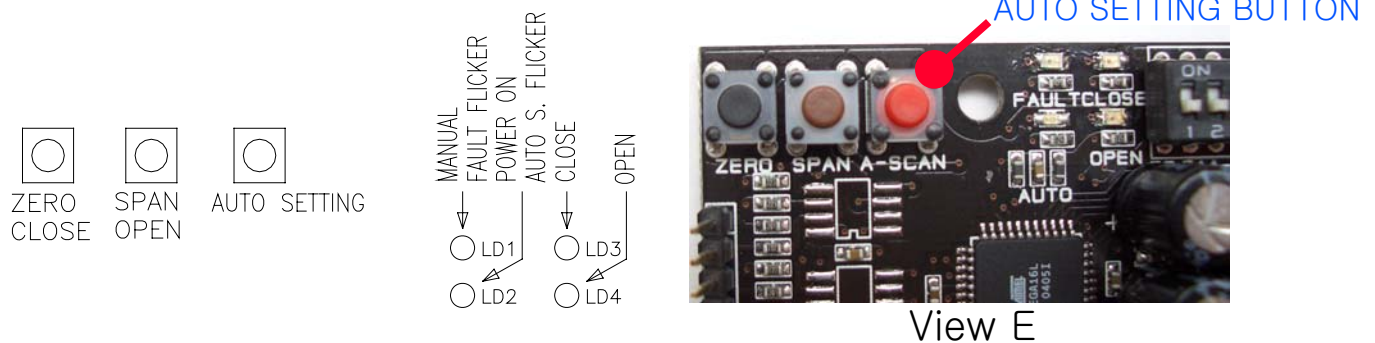

8) Split range (CH1)

If customer wants to set actuator full close and full open position at a signal, and input signal is not very exact, this is useful function.

If customer wants to set actuator full close position at 5mA, supply 5mADC and actuator moves to the position.

Then put CH1 DIP switch on and push Zero button 1 time. Then actuator acknowledges that position as full close position and transmits 4mADC.

Open set is same but push Span Button.

Once setting is done, put CH1 DIP switch off.

Adjustable range is

- Close: 3 ~ 8mA DC
- Open: 16 ~ 21mA DC

By using this DIP switch, customer may set various positions at certain signal.

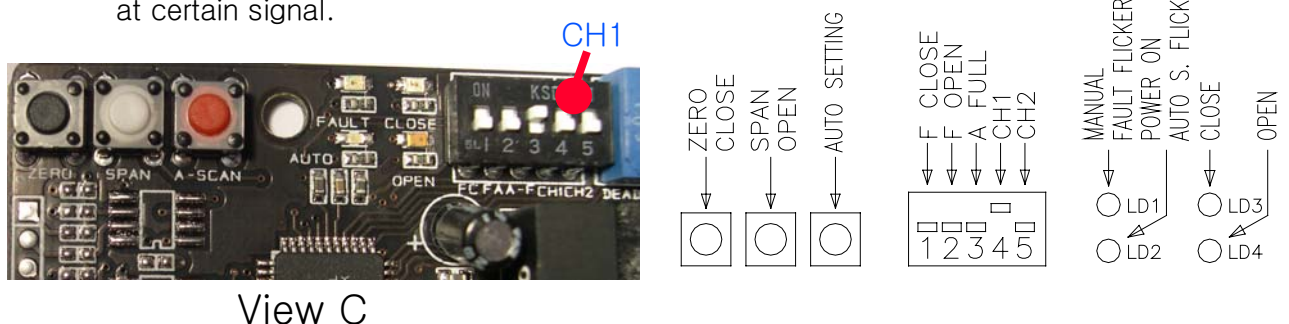

9) Reversal acting switch (CH2)

Generally clockwise-rotating direction of actuator is close but user wants reverse action, please do as follows.

- Switch "5" up = Signal: 20 mA Full Closed
- Signal: 4 mA Full Open
- Switch "5" down = Signal: 4 mA Full Closed
- Signal: 20 mA Full Open

Put actuator 50% open (or close) position, and push AUTO SETTING button.
Supplying 4~20mA, check operation and rotating direction.

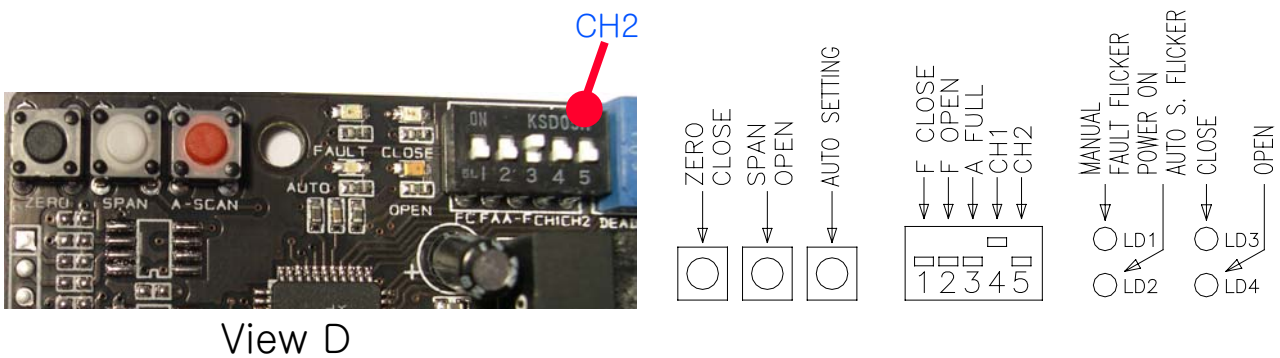

10) Selection of output signal

User can select suitable output signal by adjusting DIP switches as follows.

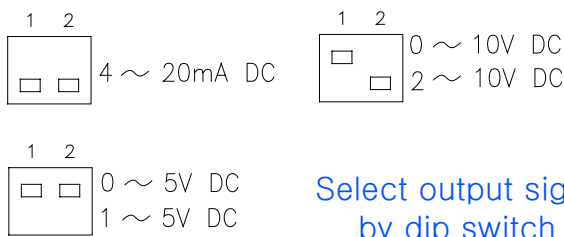

☞ If there is no instruction for the input signal, 4-20mA is set by the factory as standard signal.

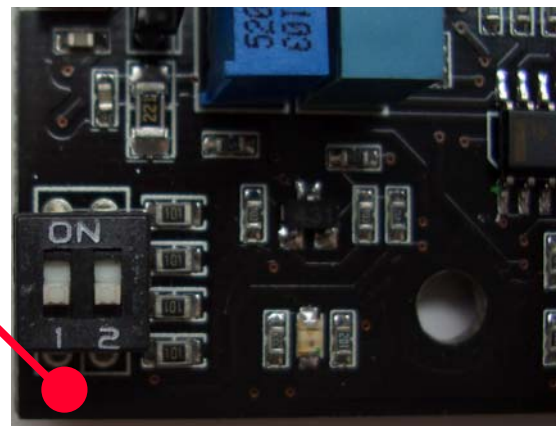

☞ adjust zero or span volume switch to meet the exact value of output signal in accordance with input signal value.

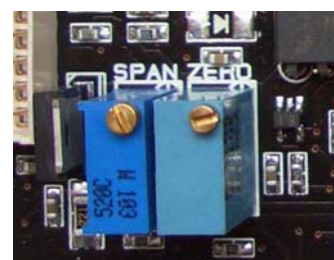

5. Special tools

- 1) L-Wrench 1 set (metric) 2) Screw driver (-) 3) Monkey spanner (1 set)
- 4) DC signal generator (0~24mADC) 5) Multi-meter 6) mA DC meter (0~25mA DC)

6. Setting potentiometer (Replacing and setting)

- 1) Put actuator full close position
- 2) Take P1 and P2 and measuring its resistance, turn potentiometer until it reach between 30 ~100Ohm.
- 3) Engage the potentiometer gear into main gear and tighten the screw.

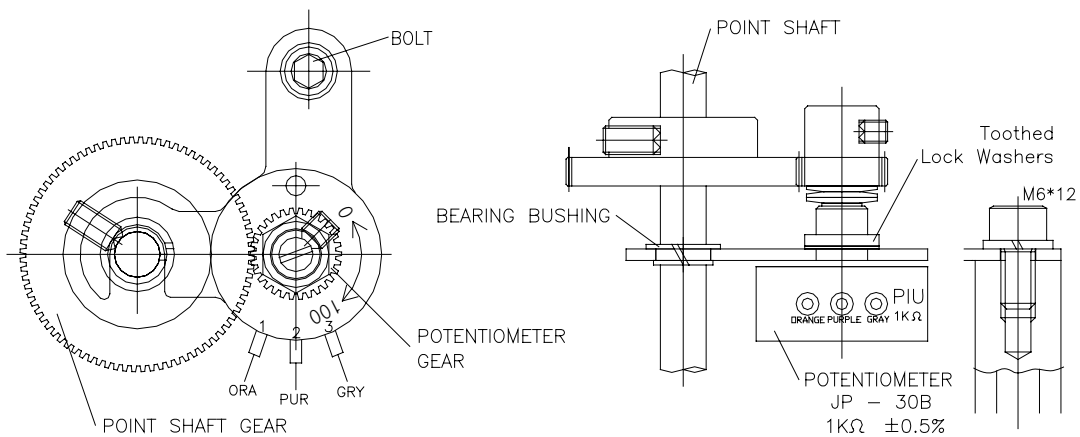

7. Limit switch setting

- ① Pull over the lever for manual operation and turn hand wheel to move actuator full close(Or open) position.
- ② Loose the bolts tightening cam by L-wrench, and turn CLS(Or OLS) cam to CW (or to CCW), so that cam may hit the lever of close(Or open) limit switch.

Then tighten the bolt by L-wrench

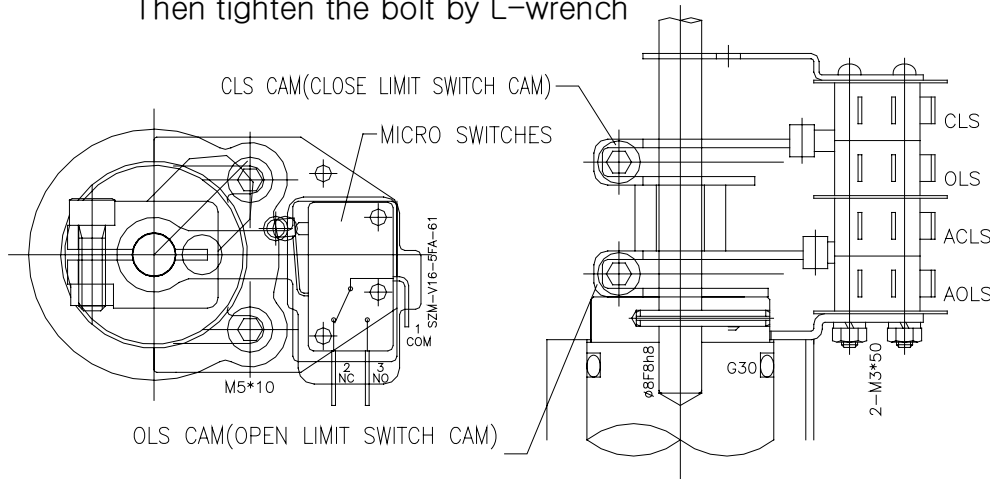

8. Check operation of PCU

Actuator	Full close	Full open
Input signal	4mA DC (1VDC, 2VDC)	20mA DC (5VDC, 10VDC)
Output signal	4mA DC	20mA DC
Signal LED	Green LED on	Red LED on
Auto setting	Blue LED flicker	
Input signal failure	Yellow LED flicker	

9. Layout of PCU CARD

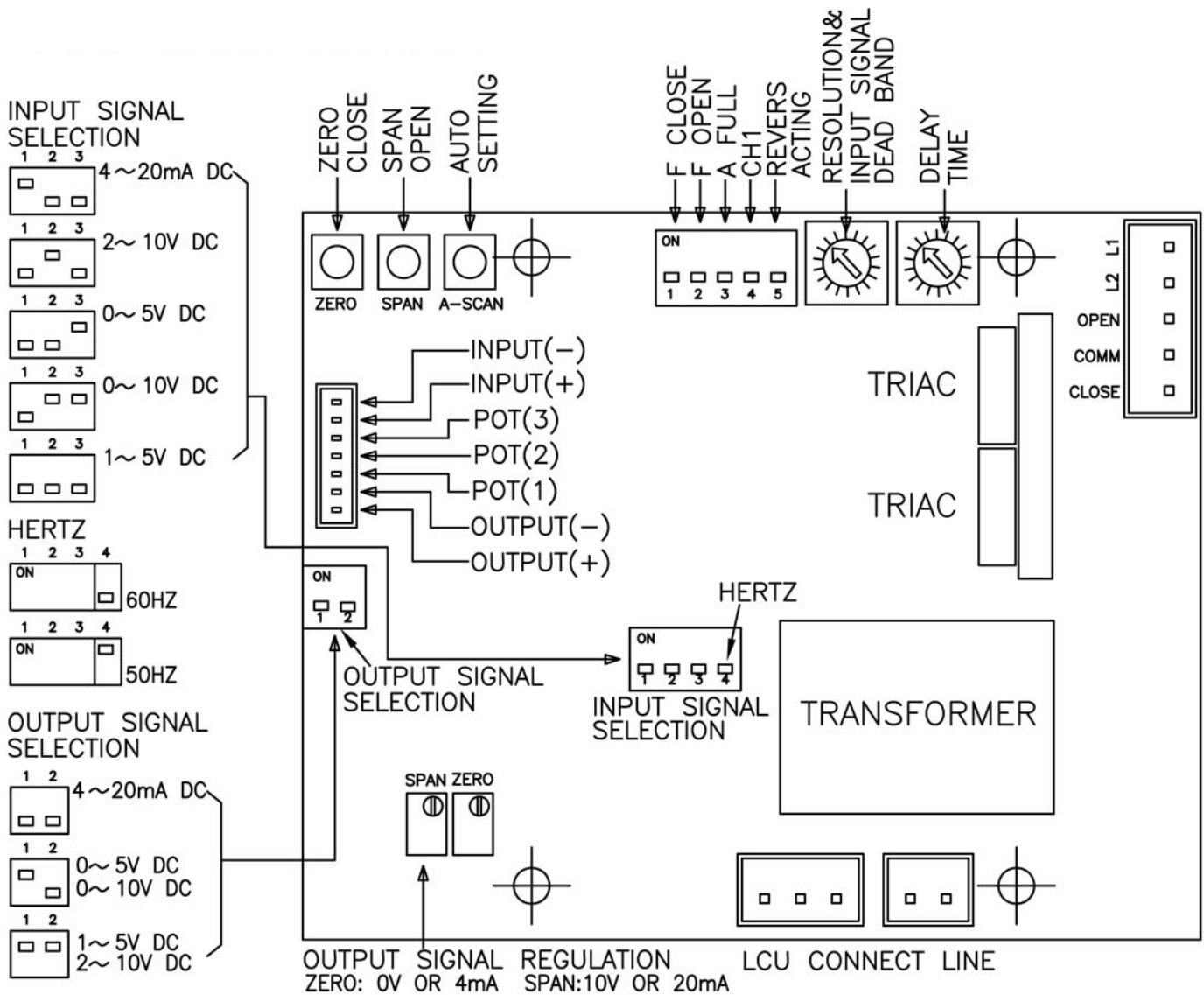

Layout of PCU CARD

View E

View A

View C

View D

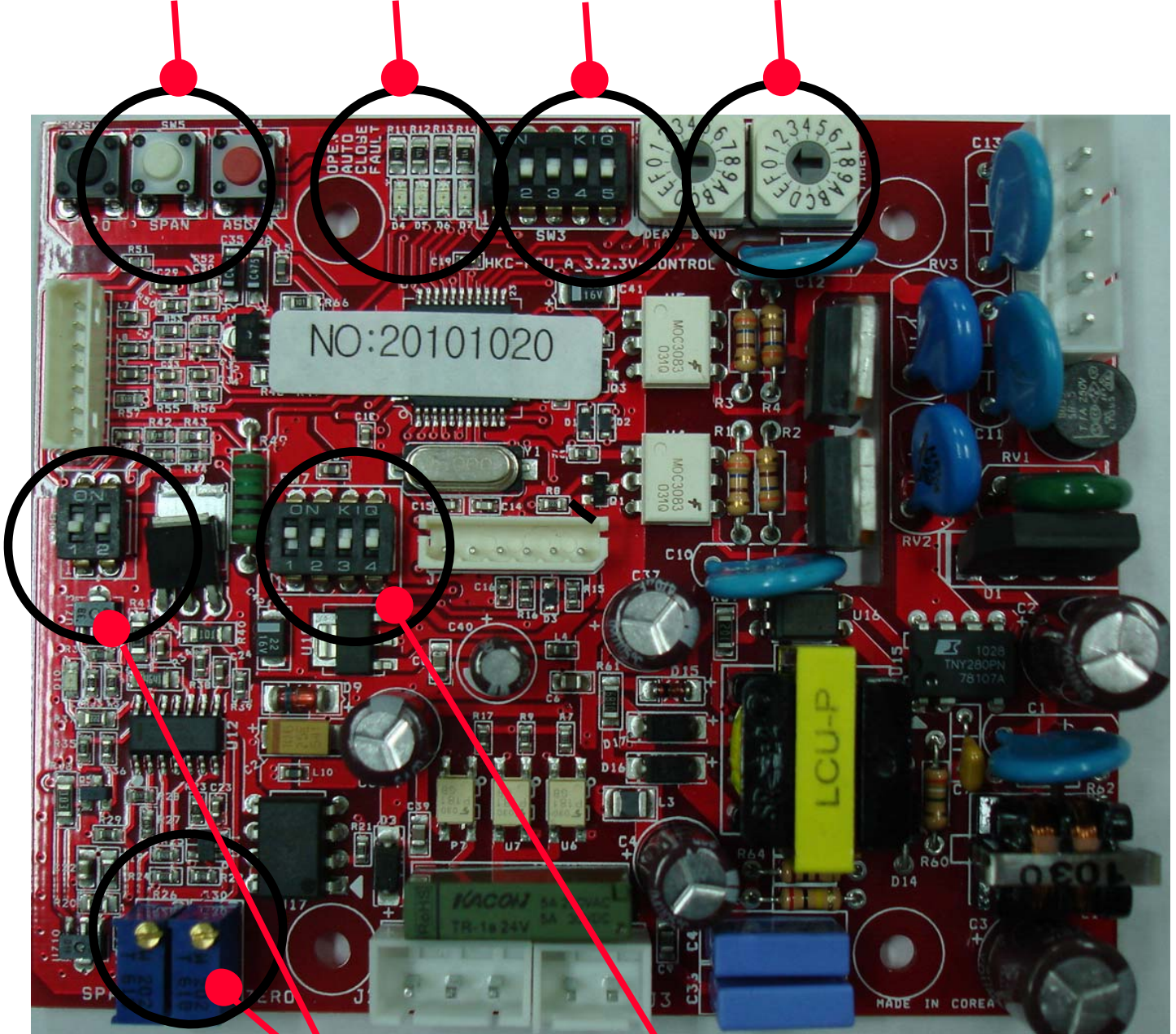

View F

View B